

THIS DOCUMENT CONTAINS PROPRIETARY INFORMATION WHICH IS THE PROPERTY OF QSC, LLC. THAT MAY NOT BE DISCLOSED, REPRODUCED OR USED WITHOUT EXPRESS WRITTEN CONSENT FROM QSC, LLC.

REVISIONS			
REV	DESCRIPTION	BY	DATE
A	RELEASE FOR SALES AND MARKETING	SS	3-OCT-16

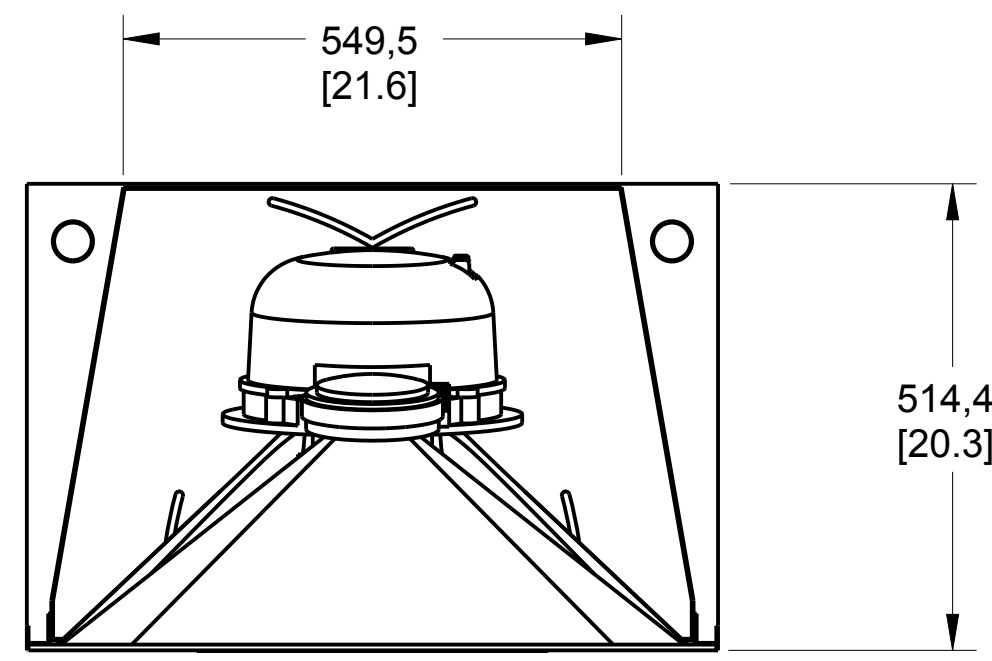

TOP

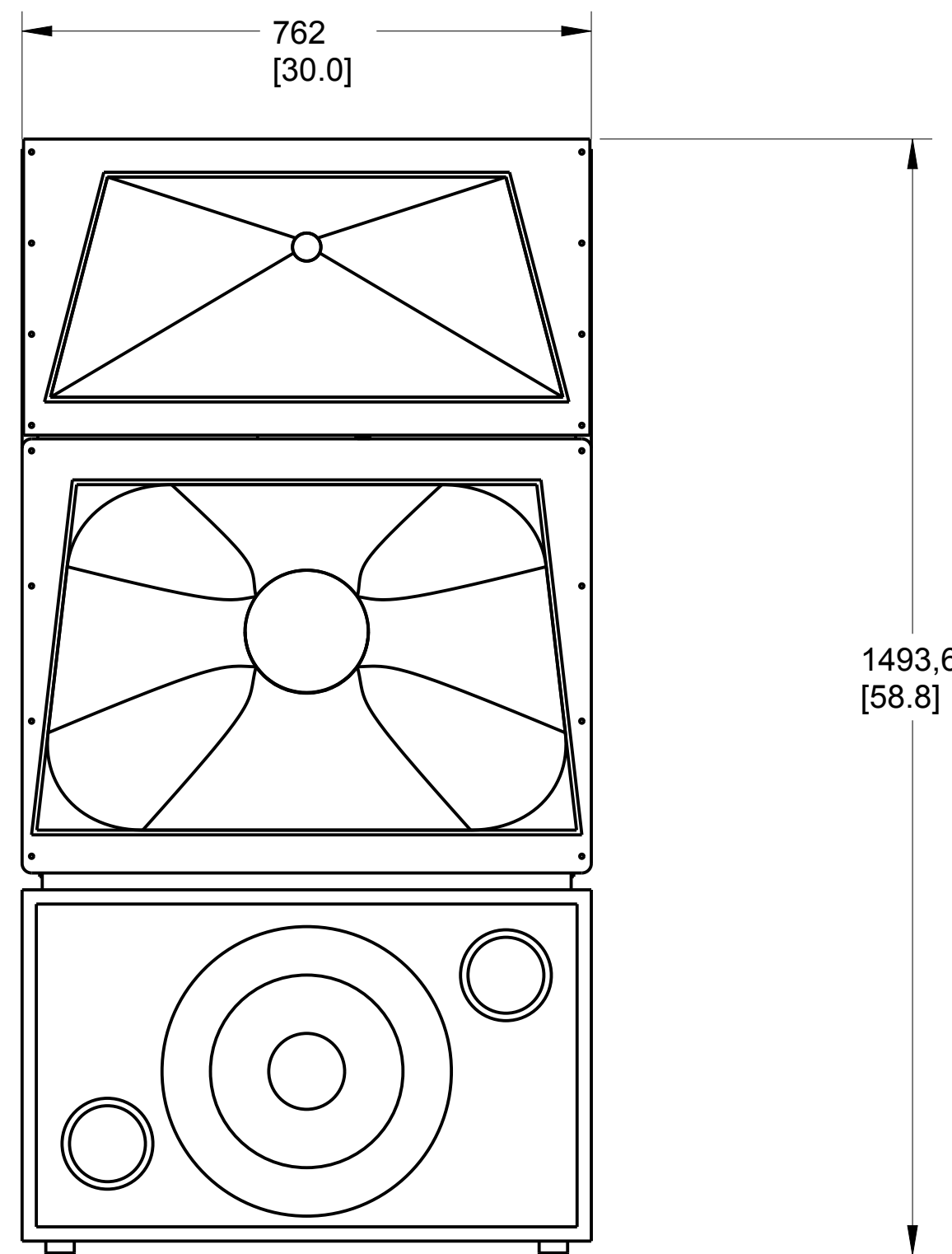

FRONT

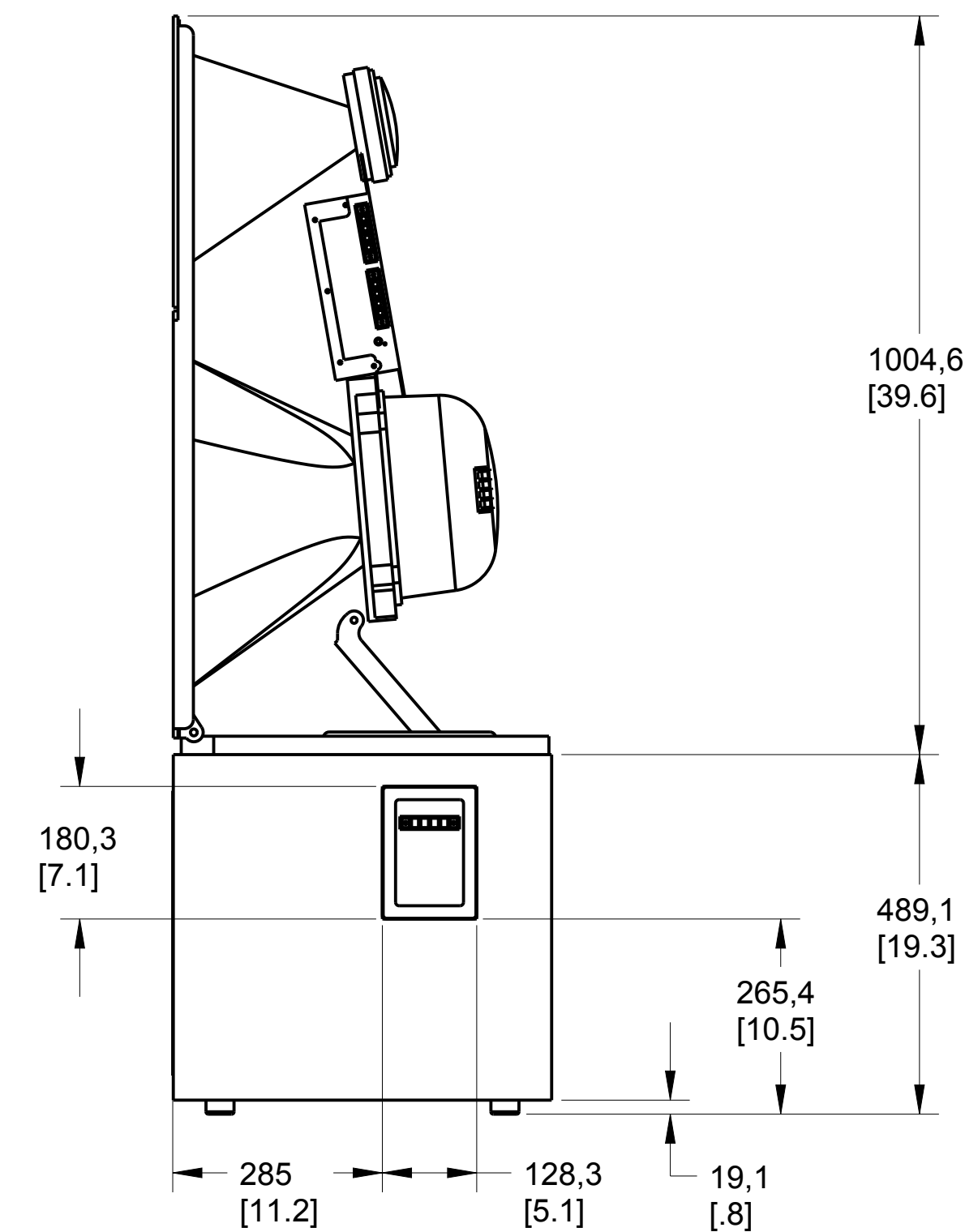

RIGHT

- 3. DIMENSIONS ARE IN MILLIMETERS [INCH].
- 2. TOLERANCES (MM): X± 3, ANGLES: ± 1°.
- 1. NET WEIGHT APPROX. 167 LBS (76.5 KG)

NOTE: UNLESS OTHERWISE SPECIFIED

UNLESS OTHERWISE SPECIFIED DIMENSIONS IN MILLIMETERS (IN) TOLERANCES ARE: DECIMALS    DECIMALS    ANGLES X± .5(.02)    XX± .25(.01)    ± 1/2 DEBURR EDGES .25 [0.01] R MAX	DESIGNER	QSC, LLC 1675 MACARTHUR BOULEVARD COSTA MESA, CA 92626	<b>SPEAKER, FINISHED, SC-414</b>		
	ENGINEERING SERVICES				
	ENGINEER				
	TECHNICAL DIRECTOR				
MATERIAL	MANUFACTURING ENGINEER	SIZE	CAGE CODE	DRAWING NO.	REV
FINISH	DRAWING INFO: DC-SC-414-2D.	D	00PW4	DC-SC-414-2D	A
	MODEL INFO: DC-SC-414-3D.A.0	SCALE: 0.120	DO NOT SCALE DRAWING	SHEET	1 OF 1