

4

3

2

1

B

B

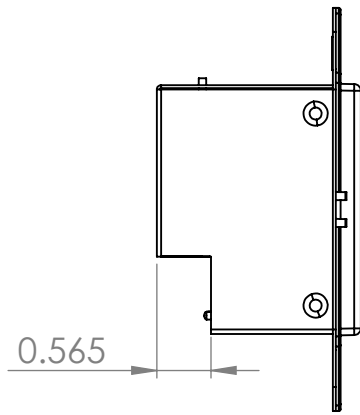
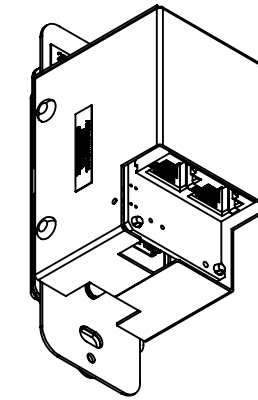
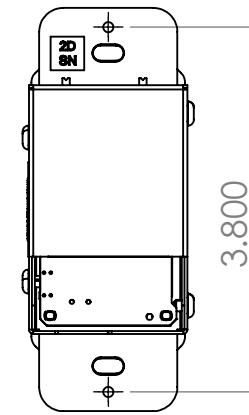
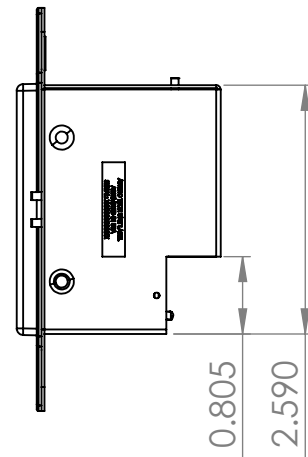
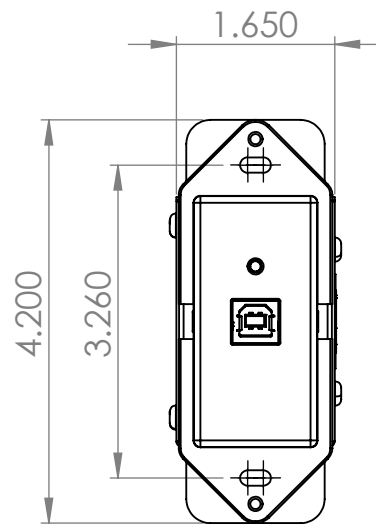
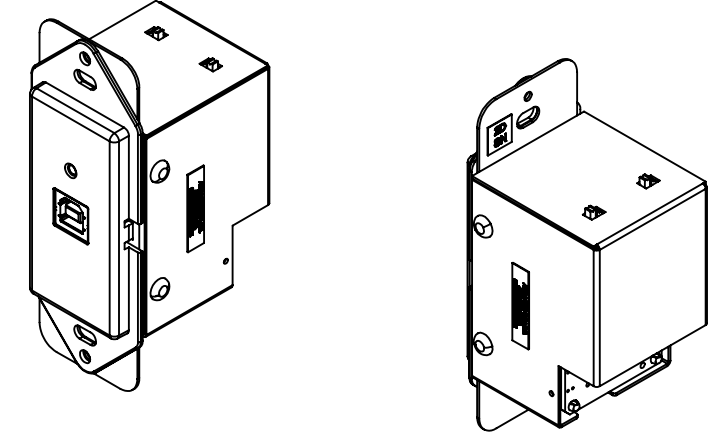
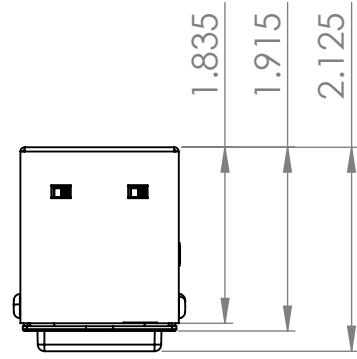

A

A

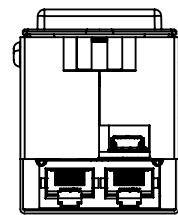

MATERIAL:		CLIENT NAME: (C) 2020 ATTEROTECH		
FINISH:		PART NO. 711-00012-01		
UNLESS OTHERWISE SPECIFIED: DIMENSIONS ARE IN INCHES TOLERANCE: ANGLE +/- 1 DEG X.XX= +/- 0.01" X.XXX= +/- 0.010" DO NOT SCALE DRAWING	DESIGNER MCH	DATE 02/11/2020	DESCRIPTION INST DWG, ATTERO TECH, AXIOM USB1, US	
	CUSTOMER	DATE		
THE INFORMATION CONTAINED IN THIS DOCUMENT IS ISSUED IN STRICT CONFIDENCE AND SHALL NOT, WITHOUT PRIOR WRITTEN PERMISSION OF THE CLIENT BE REPRODUCED, COPIED OR USED FOR ANY PURPOSE WHATSOEVER AND MUST BE RETURNED UPON REQUEST.	MFG	DATE	SIZE B	CUST NO.
	APPROVED	DATE	DWG. NO. 711-00012-01	DOC REV. 1.0
			SCALE 1:1	SHEET TITLE
			SHEET 1 OF 1	

4

3

2

1